

Overview

Weatherproof digital UK₀ call station Explosion-proof (WFD-EXPROOF)

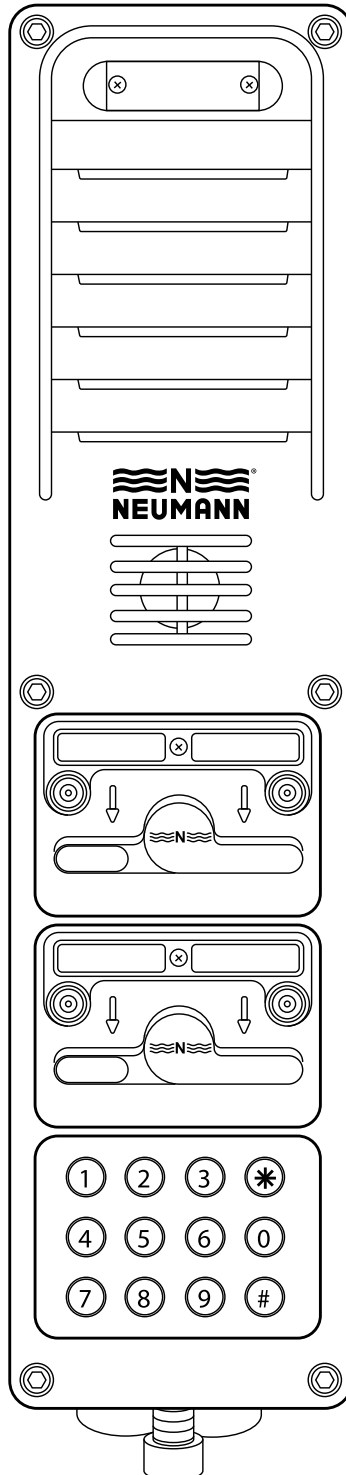

1 564 6

Weatherproof digital UK₀ call station, explosion-proof (WFD-EXPROOF)
Edition 01-2020 / Page 1
© Neumann Elektronik GmbH

Ver. 31.12.20 17:10



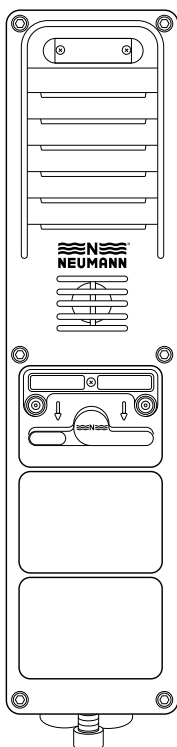

**WFD EXPROOF
station,
1 double toggle
Art.-No. 1 564 6**

**as before,
with additional amplifier
Art.-No. 1 561 3**

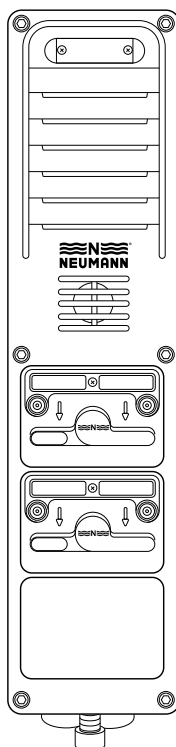

**WFD EXPROOF
station,
2 double toggle
Art.-No. 1 565 7**

**as before,
with additional amplifier
Art.-No. 1 562 4**

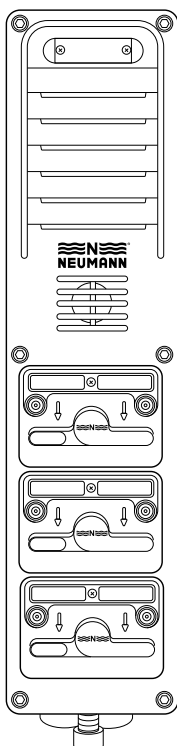

**WFD EXPROOF
station,
3 double toggle
Art.-No. 1 563 5**

**as before,
with additional amplifier
Art.-No. 1 560 2**

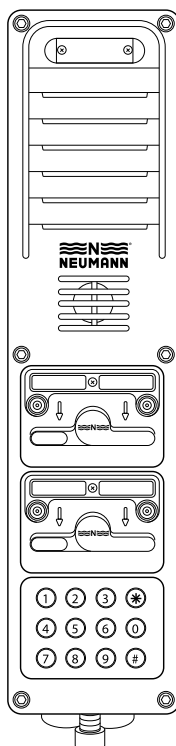

**WFD EXPROOF
station,
2 double toggle
Dialling keypad
Art.-No. 1 521 9**

**as before,
with additional amplifier
Art.-No. 1 522 0**



1 564 6

Weatherproof digital UK₀ call station, explosion-proof (WFD-EXPROOF)
Edition 01-2020 / Page 2
© Neumann Elektronik GmbH

Ver. 31.12.20 17:10

NEUMANN

Established Neumann Elektronik quality

Full compatibility with DS-6 system via UK₀ adapter

Two-wire technology with 6 km range

Noise-compensated electret microphone

25W / 100Volt additional amplifier¹⁾ solderless installation possible on site

Integrated loudspeaker designed as pressure chamber system

Service-friendly modular design thanks to bolting system

EX-protection through pressure resistant encapsulation

Fully metallised inner housing prevents electromagnetic incompatibility (EMV)

Dial keypad and double toggle intercom keys can be upgraded and replaced thanks to „plug & play“

Microphone sensitivity as well as integrated loudspeaker and 25 Watt additional amplifier¹⁾ directly adjustable on site

EL mode with own additional loudspeaker¹⁾ standard

Dust and waterproof, glass fibre reinforced polyester housing

1) can be ordered optionally



1 564 6

Weatherproof digital UK₀ call station, explosion-proof (WFD-EXPROOF)
Edition 01-2020 / Page 3
© Neumann Elektronik GmbH

Ver. 31.12.20 17:10

The Neumann logo consists of three wavy lines above the word 'NEUMANN' in a bold, sans-serif font.

Established Neumann Elektronik quality

Double toggle intercom buttons with opto-coupler, 2 lines each

Generous connection space, two wires per connection can be clamped

Line keys can be freely assigned as destination keys

Dialling function with dialling keypad, can optionally be used as destination keys without illumination

Temperature-controlled power limitation of the 25W auxiliary amplifier¹⁾

Indication of busy and call indication by LEDs

Mounting takes place after lifting off the housing cover through 4 mounting holes in the basic housing

Standard lower-priority circuit

Switchable volume reduction e.g. for night operation

Switch-off of the additional loudspeaker¹⁾ after the first WL response as standard

Cable gland for additional loudspeaker cable as standard

Low power consumption

Potential-free contact for controlling a flash lamp or horn

1) can be ordered optionally / may require an additional two-wire cable



1 564 6

Weatherproof digital UK₀ call station, explosion-proof (WFD-EXPROOF)
Edition 01-2020 / Page 4
© Neumann Elektronik GmbH

Ver. 31.12.20 17:10

The Neumann logo consists of three wavy lines above the word 'NEUMANN' in a bold, sans-serif font.

The explosion-proof, weatherproof digital UK₀ WFD EXPROOF call stations enable direct speech connections with other call stations and loudspeaker announcements in potentially explosive environments.

By pressing the robust double toggle intercom buttons, light barriers (opto-couplers) are activated without contact, which allows permanent use in aggressive, humid and also dusty environments, especially in areas with explosive gases and dusts. For special applications, the call station can optionally be manufactured with a protective lacquer. Please contact us for more information.

The call stations are intended for wall mounting and must be earthed. In cases where wall mounting is not possible, an optional stand column is available.

The WFD EXPROOF UK₀ call stations cannot be extended with additional housings.



Physical data

Dimensions (H x B x T)	500 x 120 x 180 mm
Weight (without auxiliary amplifier)	approx. 6,5 kg
Colour	pure orange (RAL 2004)
Housing flammability	UL94 V-0 (3,2)

Electrical data

Nominal operating voltage	DC 48 V
max. quiescent current	≤ 25 mA
max. operating current	≤ 100 mA
Frequency range	300 Hz bis 7 kHz
Transmission protocol	Neumann-WL-protocol
Potential-free two-way contact	DC 30 V, 500 mA

Environmental conditions

Ambient temperature range	-20°C bis +55°C
ATEX Type of protection gas	 II 2 G Ex db eb ib IIC T4
ATEX Type of protection dust	 II 3 D Ex tc IIIB T135°C
EU-TYPE-EXAMINATION CERTIFICATE	PTB 01 ATEX 2070 X
IECEX Type of protection gas	IEC Ex db eb ib IIC T4
IECEX Type of protection dust	IEC Ex tc IIIB T135°C
IECEX Certificate of Conformity	IECEX PTB 16.0036X



1 564 6

Weatherproof digital UK₀ call station, explosion-proof (WFD-EXPROOF)
Edition 01-2020 / Page 5
© Neumann Elektronik GmbH

Ver. 31.12.20 17:10

Accessories

Art.-No.	Article	Description
3 334 3	DS-6 UK ₀ Adapter	To connect to the DS-6 system
1 570 3	25 W Auxiliary Amplifier	25 W / DC 48 V
1 950 5	Stand	to use the call station as a pillar
64 9 0109 031 3	Outdoor acoustic hood	Sound absorbing bonnet for outdoor use
64 9 0109 004 3	Indoor acoustic hood	Sound absorbing bonnet for indoor use
22 9 0501 560 0	Mounting Kit	Adapter for mounting holes of older microphone units, incl. 2 mounting brackets and 4 hexagon screws V2A M6 x 18
61 3 1831 007 0	Blank Panel	Instead of a double toggle intercom button
22 2 1601 560 5	Key insert	Instead of a dialling keypad
22 3 0101 681 4	Dialling keypad	Instead of a double toggle intercom button
97 9 4413 561 9	Hexagon socket screw wrench SW5	For hexagon socket screws on housing panel
4 972 2	15 Watt Ex Loudspeaker	Explosion-proof chamber loudspeaker
4 973 3	25 Watt Ex Loudspeaker	Explosion-proof chamber loudspeaker



1 564 6

Weatherproof digital UK₀ call station, explosion-proof (WFD-EXPROOF)
Edition 01-2020 / Page 6
© Neumann Elektronik GmbH

Ver. 31.12.20 17:10

The Neumann logo features the word 'NEUMANN' in a bold, sans-serif font. Above the letters 'N' and 'M' are three horizontal wavy lines, resembling sound waves.

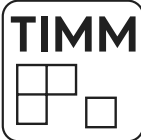

Control centre

Industrial control

Video

Telephone

Process control

Access control

Evacuation

emergency call

Personal radio

Fire alarm system

Intercom

Emergency exit control

Public address system

Radio

Building services engineering

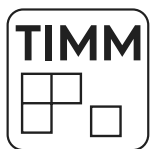

TIMM ComServer

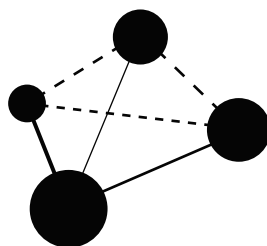

IP network



1-n

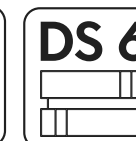
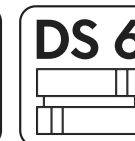
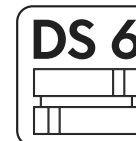
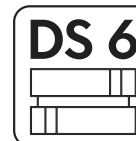
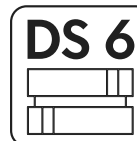
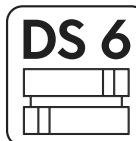

1-n

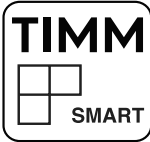

↓↑



↓↑



↓↑



↓↑



I/O Modul
NE 4 475 0

↓↑



CANopen

↓↑

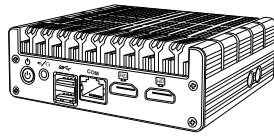

NE 3 358 9
TIMM SMART



WEB Server



Config / state



SNMP / MIB

Com Server Application

Gateway Application

Speechbox*	NE 5 067 8
SIP-Trunk*	NE 5 065 6
Phone Server*	NE 5 034 2
MODBUS / TCP-IP*	NE 5 068 9
CANopen*	NE 3 373 6

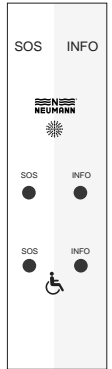

←
→
NIS

↓↑

DS 6 U_{k0} II Adapter NE 3 334 3

and / or

DS 6 PA Control I NE 3 342 2

and / or

DS 6 PA Control II NE 3 343 3

and / or

DS 6 Analog adapter x8 NE 3 331 0

and / or

DS 6 Plug-in unit analog NE 2 390 4

and / or

DS 6 PACE EN 54-16 NE 3 344 4

DS 6 PC Call station „all-in-one“ NE 1 296 8

DS 6 MTSD Call station NE 1 045 0

DS 6 MTSD IP42 Call station NE 1 0854

DS 6 Intercom call station (rack-mounted)
NE 1 278 8
NE 1 279 9

DS 6 Call station (panel-mounted) NE 1 28X X¹

DS 6 Crane call station NE 1 156 3

DS 6 WFD IP Call station NE 1 5XX X¹

DS 6 WFD IP Compact call station NE 1 87X X¹

¹⁾: various models; product numbers depending on individual requirements.

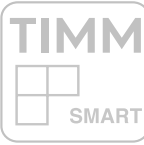

I/O Modul
NE 4 475 0

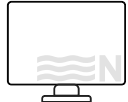

PC Call station
„all-in-one“
NE 1 296 8

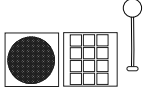

Built-in call station
(panel assemblies)
NE 1 29X X¹



MTSD IP42
Call station
NE 1 085 4



MTSD
Call station
NE 1 045 0

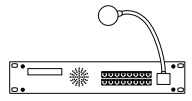

Rack mounting station
19 Zoll
NE 1 27X X¹

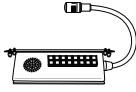

Crane call station
NE 1 156 3



WFD IP
Weatherproof
compact call station
NE 1 87X X¹



WFD IP Weatherproof
intercom station
NE 1 59X X¹
NE 1 681 6

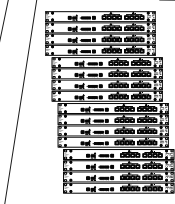
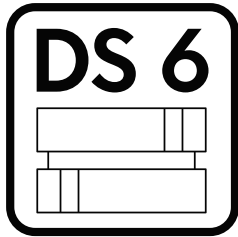

U_{k0} II Adapter 8x
NE 3 334 3



MTSD
U_{k0} Call Station
NE 1 84X X¹

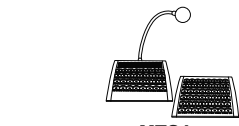

MTSA
Call station
NE 1 75X X¹



LK1 - LK4

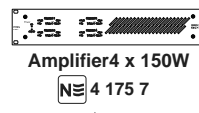

Amplifier 4 x 150W
NE 4 175 7



UHF (Ultra High Frequency)



Third-Party
Hardware



PA Control II
NE 3 343 3

PA Control II
NE 3 343 3

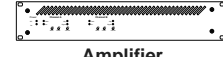

Amplifier
NE 4 1XX X¹



Amplifier
NE 4 1XX X¹

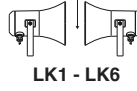

LK1 - LK6

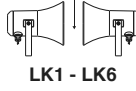

LK1 - LK6



Amplifier
50Watt
NE 4 150 0

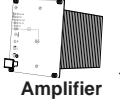

Amplifier
100 Watt
NE 4 160 1

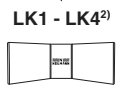

Diffuse emitter
NE 4 805 7



Diffuse emitter
NE 4 805 7

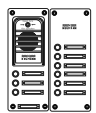

WFAK Analogue
call station compact
WFAK Additional housing
NE 1 9XX X¹

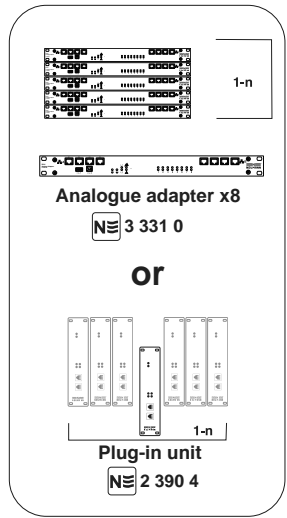

Analogue adapter x8
NE 3 331 0

Plug-in unit
NE 2 390 4

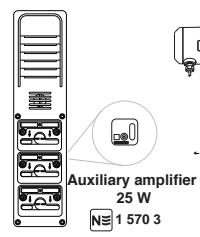

WFA
Weatherproof call station
NE 1 5XX X¹

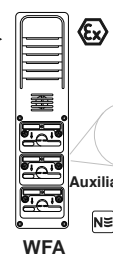

WFA
Weatherproof call station
NE 1 5XX X¹



WL 1 Watt
Universal amplifier
NE 1 841 4



1) different models;
product numbers according to
individual requirements
2) optional

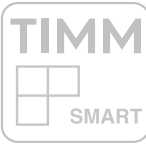

tunnel horn/ boundary horn speaker
NE 4 76X X

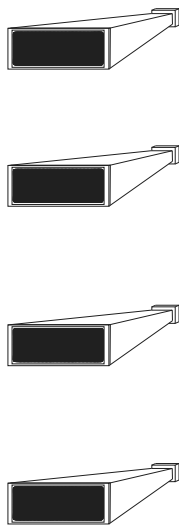

tunnel horn/ boundary horn speaker
NE 4 76X X

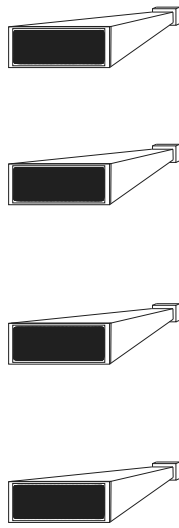

Desktop call station PACE-CSTP
DIN EN 54-16, Touch screen
NE 1 357 6

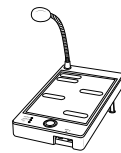

Desktop call station PACE-CS20
DIN EN 54-16, 20 Keys
NE 1 355 4

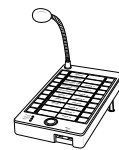

Voice alarm center unit
PACE-VA, EN54-16
NE 3 344 4

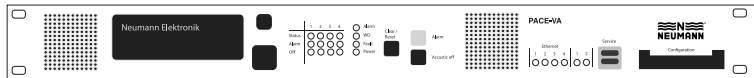

1-n



I/O Modul
NE 4 475 0

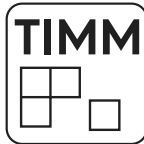

MODBUS
TCP-IP

CANopen

Emergency call station
NE 1 0XX X¹⁾

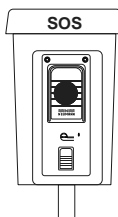

1-n

Control center
(OMC)
1-n

MTSD
Desktop call station
NE 1 045 0



PC call station
„all-in-one“
NE 1 296 8



I/O Modul
NE 4 475 0



Analogue adapter x8
NE 3 331 0

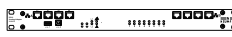

1-n

¹⁾ different models; product numbers according to individual requirements



Neumann Elektronik GmbH

**Lahnstrasse 31-33
45478 Mülheim an der Ruhr
Germany**

**info@neumann-elektronik.com
www.neumann-elektronik.com**



1 564 6

Weatherproof digital UK₀ call station, explosion-proof (WFD-EXPROOF)
Edition 01-2020 / Page 11
© Neumann Elektronik GmbH

Ver. 31.12.20 17:10

NEUMANN